

Imaging-Based Liver Function Tests – Past, Present and Future

Bildgestützte Leberfunktionstests – Stand der Technik und zukünftige Entwicklungen

Authors

D. Geisel¹, L. Lüdemann², B. Hamm¹, T. Denecke¹

Affiliations

¹ Department of Diagnostic and Interventional Radiology, Charité, Campus Virchow-Klinikum, Berlin, Germany

² Department of Medical Physics, Essen University Hospital, Essen, Germany

Key words

- ◉ abdomen
- ◉ MR functional imaging
- ◉ MR imaging
- ◉ SPECT
- ◉ radionuclide imaging
- ◉ laboratory tests

received 3.12.2014
accepted 2.5.2015

Bibliography

DOI <http://dx.doi.org/10.1055/s-0035-1553306>
Published online: 31.7.2015
Fortschr Röntgenstr 2015; 187: 863–871 © Georg Thieme Verlag KG Stuttgart · New York · ISSN 1438-9029

Correspondence

Dr. Timm Denecke

Department of Diagnostic and Interventional Radiology, Charité, Campus Virchow-Klinikum
Augustenburger Platz 1
13353 Berlin
Germany
Tel.: ++49/30/450557001
Fax: ++49/30/450557901
timm.denecke@charite.de

Abstract

Preoperative assessment of liver function and prediction of postoperative functional reserve are important in patients scheduled for liver resection. While determination of absolute liver function currently mostly relies on laboratory tests and clinical scores, postoperative remnant liver function is estimated volumetrically using imaging data obtained with computed tomography (CT) or magnetic resonance imaging (MRI). Accurate estimation of hepatic function is also relevant for intensive care patients, oncologic patients, and patients with diffuse liver disease. The indocyanine green (ICG) test is still the only established test for estimating true global liver function. However, more recent tools such as the LiMAX test also allow global assessment of hepatic function. These tests are limited when liver function is inhomogeneously distributed, which is the case in such conditions as unilateral cholestasis or after portal vein embolization. Imaging-based liver function tests were first developed in nuclear medicine and, compared with laboratory tests, have the advantage of displaying the spatial distribution of liver function. Nuclear medicine scans are obtained using tracers such as ^{99m}Tc galactosyl and ^{99m}Tc mebrofenin. Liver function is typically assessed using planar scintigraphy. However, three-dimensional volumetry is possible with single-photon emission computed tomography (SPECT-CT). Another technique for image-based liver function estimation is Gd-EOB-enhanced MRI. While metabolism of Gd-EOB in the body is similar to that of ICG and mebrofenin, its distribution in the liver can be displayed by MRI with higher temporal and spatial resolution. Moreover, MRI-based determination of liver

function can be integrated into routine preoperative imaging. This makes MRI an ideal candidate for preoperative determination of liver function, though the best pulse sequence and the parameter to be derived from the image information remain to be identified. Another question to be answered is how the results may be affected by renal function and the presence of hyperbilirubinemia. As more results from clinical evaluation including comparison with postoperative liver function data become available, image-based liver function tests, especially with use of Gd-EOB as the contrast medium, have the potential to add another dimension to preoperative imaging.

Key Points:

- ▶ Liver function consists of a multitude of subfunctions such as biotransformation, excretion and storage.
- ▶ Global liver function tests are score-based tests such as Child-Pugh or MELD as well as the ICG- and LiMAX-test.
- ▶ Imaging-based liver function tests add spatial information. Current clinical standard is the ^{99m}Tc-Mebrofenin-scintigraphy.
- ▶ MRI-based function tests with Gd-EOB-DTPA have the potential to integrate seamlessly into clinical workup, feature a higher temporal and spatial resolution and do not rely on ionizing radiation.

Citation Format:

- ▶ Geisel D, Lüdemann L, Hamm B et al. Imaging-Based Liver Function Tests – Past, Present and Future. Fortschr Röntgenstr 2015; 187: 863–871

Zusammenfassung

Die Bestimmung der Leberfunktion und die Abschätzung der postoperativen Leberfunktion

spielt insbesondere vor leberresezierenden Eingriffen eine große Rolle. Zur Bestimmung der absoluten Funktion werden gegenwärtig überwiegend laborchemische Parameter bzw. klinische Scores angewandt, die Abschätzung der postoperativen Funktion erfolgt dann über eine Volumetrie anhand von CT oder MRT-Daten. Auch in der Intensivmedizin, der Onkologie oder bei diffusen Lebererkrankungen hat die Bestimmung der Leberfunktion eine Relevanz. Als echter globaler Leberfunktionstest konnte sich bisher nur der ICG-Test durchsetzen, neuere Entwicklungen wie beispielsweise der LiMAX-Test können ebenfalls die Gesamtkapazität der Leberfunktion abschätzen. An ihre Grenzen kommen diese Methoden bei einer inhomogenen Funktionsverteilung wie beispielsweise bei einer einseitigen Cholestase oder nach einer Pfortaderembolisation. Bildgestützte Leberfunktionstests stammen ursprünglich aus der Nuklearmedizin und haben gegenüber laborchemischen Tests den Vorteil, dass die räumliche Verteilung der Leberfunktion mitabgebildet werden kann. Als nuklearmedizinische Tracer stehen ^{99m}Tc -Galaktosyl und ^{99m}Tc -Mebrofenin zur Verfügung, überwiegend erfolgt die Darstellung mittels planarer Szintigraphie, jedoch ist auch eine dreidimensionale Messung mittels SPECT-CT möglich. Eine weitere Möglichkeit zur bildgestützten Leberfunktionsmessung ist das Gd-EOB-verstärkte MRT. Gd-EOB wird vergleichbar zur ICG und Mebrofenin verstoffwechselt, lässt sich aber durch die MRT zeitlich und räumlich höher aufgelöst darstellen und in die präoperative Routinebildgebung integrieren. Dies prädestiniert es zur Evaluation der Leberfunktion, jedoch muss die optimale Sequenz und der hieraus abgeleitete Parameter noch gefunden werden. Offene Fragen bestehen darüber hinaus im Einfluß der Nierenfunktion und einer Hyperbilirubinämie. Mit zunehmender klinischer Evaluierung und dem Vergleich mit postoperativen Funktionsdaten haben bildgestützte Leberfunktionstests, insbesondere mit Gd-EOB, das Potential, die präoperative Bildgebung um eine weitere Dimension zu bereichern.

Development of Imaging-Based Liver Function Tests

The liver as the central metabolic organ assumes a wide range of functions in the organism including synthesis of proteins and coagulation factors, storing of vitamins and glycogens, elimination of bilirubin, medications, and bile salts, and immunological functions via the Kupffer cells. There is a significant need to determine functional capacity. It is relevant for risk assessment prior to liver resection, follow-up after liver transplantation, and monitoring of chronic liver diseases. In correlation with the plurality of subfunctions, clinical scores as well as a number of global liver function tests were developed with the most well-known test being the indocyanine green test including measurement of the ICG clearance rate [1]. However, a test that has been generally established in the clinical routine has not yet been developed [1–3]. In addition to ease of use, a decisive criterion for such a test is significant correlation with the clinical course or postoperative liver failure in cases of risk assessment prior to liver resection.

The role of radiology was previously primarily liver resection planning with determination of the total liver volume and the presumed postoperative liver volume (FLR – future liver remnant) as a surrogate marker for liver function and enlargement of the FLR via preoperative portal vein embolization (PVE) in patients with an insufficient liver remnant.

The risk of postoperative liver failure due to an insufficient functional liver volume continues to be one of the greatest risks in modern liver surgery, particularly in the case of extended right resection, in patients with a damaged liver parenchyma, and in the case of preexisting liver cirrhosis [4–6]. As a result of the increasingly radical surgical methods, PVE has become standard in patients with insufficient postoperative liver volume [7, 8]. The challenges for radiology and surgery are selecting patients who profit from PVE, monitoring the increase in function, and determining the optimal time point for liver resection. Any delay of surgery due to PVE should be kept as minimal as possible from an oncological perspective since tumor progression would be in direct conflict with the planned curative approach by radical surgical therapy [9]. An alternative approach to enlarging the FLR is the *in situ* split technique [10]. In a two-step surgical approach, the FLR is first separated from the liver volume to be resected to prevent collateralization and the right portal vein branch was ligated. In a second step approximately two weeks later, definitive resection is performed. However, the invasiveness and complication rate are significantly higher than in the case of PVE.

At present, only the volume increase but not the functional capacity of the non-embolized liver half is measured. For this purpose, CT or MRI examinations are performed before and 4–6 weeks after portal vein embolization. If a sufficient increase in volume is determined, definitive surgery is performed [8, 11]. This approach assumes uniform distribution of liver function in the liver volume that cannot be clearly identified as tumor. However, this can no longer be assumed after portal vein embolization (► Fig. 1). As systematically shown for the first time by de Graaf et al., the increase in function exceeds the volume increase [12]. Global liver function tests such as the ICG test and clinical scores reach their limit here since only the total functional capacity of the liver can be measured.

Imaging-based liver function tests represent an alternative for determining liver function with the possibility of measuring function in parts of the liver [13, 14]. They are based on the intravenous application of pharmacological substances that are absorbed by hepatocytes and are degraded or excreted in bile. Using nuclear medicine or radiological methods, the drug concentration is measured via planar images (gamma camera) or cross-sectional imaging (SPECT/CT or MRI). This can be performed at a fixed point in time after application or dynamically to determine kinetics. Nuclear medicine techniques followed by radiological methods will be discussed in the following.

Nuclear medicine techniques

In recent decades, different nuclear medicine tracers for determining liver function have been developed. One of the first was ^{131}I -rose bengal, which is currently no longer used due to the high β -radiation [15]. Current hepatobiliary tracers are based on ^{99m}Tc . ^{99m}Tc -galactosyl (GSA) and ^{99m}Tc -mebrofenin are used for imaging-based liver function measurement [14, 16].

The asialoglycoprotein receptor is expressed exclusively on hepatocytes of mammals and is specific for asialoglycopro-

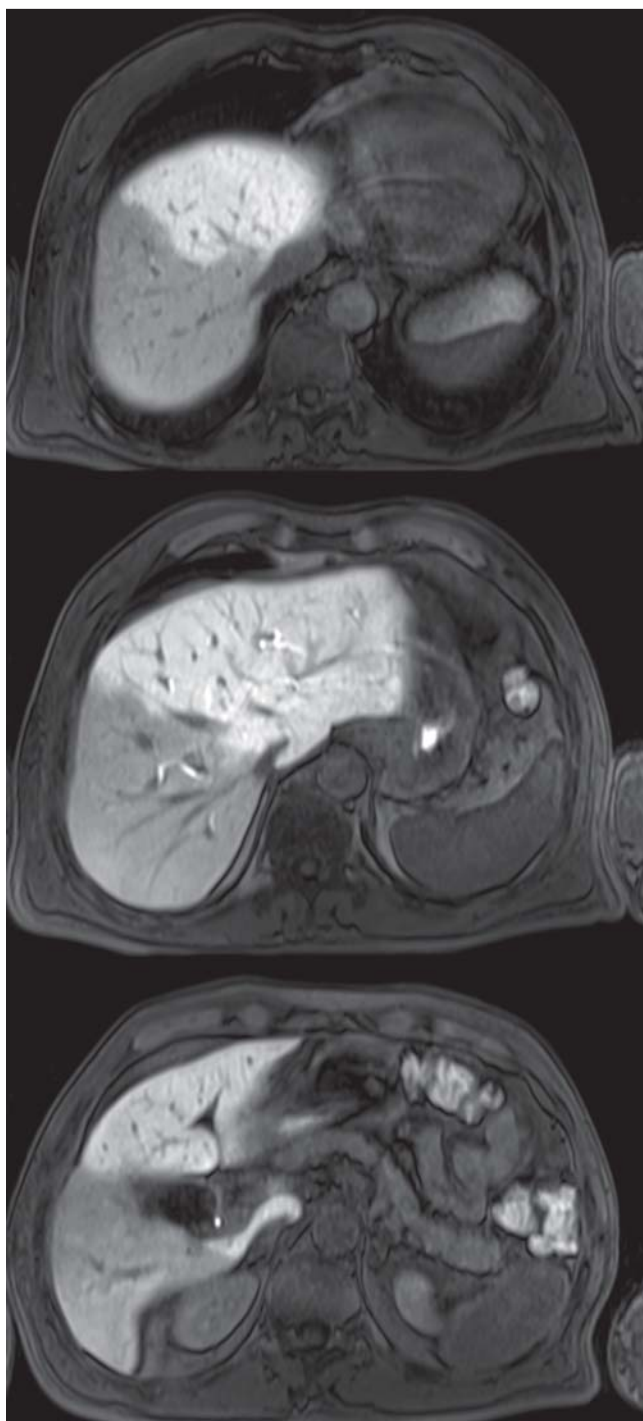

Fig. 1 Gd-EOB-enhanced MRI 4 weeks after right portal vein embolization, T1-VIBE sequence after 20 minutes with flip angle of 30°. MRI with an increased excitation angle clearly shows the different signal intensities of the embolized and the non-embolized liver segments corresponding to a different function ratio.

teins. The receptor is expressed on the sinusoidal surface of hepatocytes, known as the perisinusoidal space [17]. Asialoglycoproteins bind to the asialoglycoprotein receptor and are absorbed by the hepatocytes via receptor-mediated endocytosis and are then broken down in the lysosome [14]. In the case of chronic liver diseases, there is a significant decrease in the concentration at the asialoglycoprotein receptors [18, 19]. The synthetic ^{99m}Tc -coupled asialoglycopro-

tein ^{99m}Tc -GSA as a suitable tracer is currently only used in Japan [19].

IDA analogs for hepatobiliary scintigraphy were first described in 1976 by Lobert et al. [20]. Today, mebrofenin is the most important substance in this group since it has the highest specificity for hepatocytes [21]. All IDA analogs are bound to albumin and transported to the liver and then dissociate again in the perisinusoidal space. They are then absorbed by the hepatocytes via organic anion-transporting polypeptides (OATP) 1B1 and 1B3 and are eliminated in bile. This occurs without prior biotransformation primarily as a result of multidrug resistance protein (MRP) 2 [20, 22, 23]. The IDA analogs share their metabolic pathway with a number of endogenic and exogenic substances, such as bilirubin, medications, toxins, and hormones [24].

^{99m}Tc -GSA and ^{99m}Tc -mebrofenin are highly liver-specific and have negligible renal elimination in the case of normal serum bilirubin [18, 25].

Nuclear medicine imaging can be performed using planar methods (single or dual head gamma camera) or three-dimensionally via SPECT. SPECT acquisition allows 3D distribution analysis and the possibility to perform CT attenuation correction allows more exact measurement [14, 16]. However, it can only be used on a limited basis in the case of IDA analogs since the temporal resolution is not sufficient for the determination of kinetics and thus tracer clearance. A combination of dynamic planar imaging and an additional single SPECT acquisition to resolve this problem has therefore been described [12, 26]. The preferred parameters from the dynamic evaluation are blood-clearance rate and hepatic uptake rate for GSA and hepatic uptake rate and extraction fraction for the IDA analogs [16, 27].

Due to the shared metabolic pathway, ^{99m}Tc -mebrofenin scintigraphy correlates with the ICG tests and the postoperative liver function [26, 28, 29]. Moreover, it can detect the function increase in the non-embolized liver segment after portal vein embolization [12, 30] and is also used to determine the function of an auxiliary liver transplant (Fig. 2). Successful liver function measurement with ^{99m}Tc -GSA scintigraphy has also been described. It was able to detect an increase in function in the non-embolized liver segment after portal vein embolization and functional differences between the two liver lobes [31–34]. For example, Sumiyoshi et al. were able to show significant regional functional differences in patients with biliary drainage due to cholangiocarcinoma [34]. Prediction of the postoperative liver function and determination of the “functional liver mass” are also possible [31, 35, 36].

MRI as imaging-based liver function test

Liver-specific MRI contrast agents were actually developed for improved detection of focal liver lesions [37, 38]. In addition to the still available superparamagnetic iron oxides (SPIO) which are specific for the reticulo-endothelial system (RES), hepatocyte-specific contrast agents are increasingly being evaluated with respect to their ability to be used for an imaging-based liver function test [13].

Gadolinium ethoxybenzyl (Gd-EOB; Primovist®, Bayer AG, Berlin) and gadobenate-dimeglumine (Gd-BOPTA; MultiHance®, Bracco-Byk Gulden, Constance) are the two con-

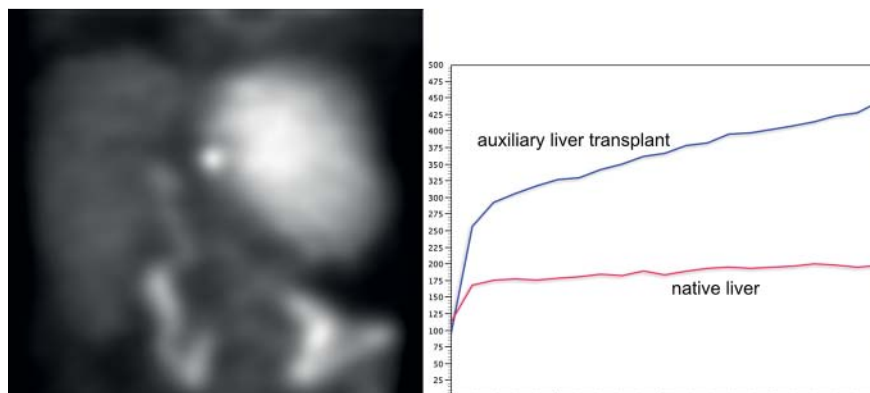

Fig. 2 ^{99m}Tc -mebrofenin scintigraphy 1 week after auxiliary liver transplantation. The left figure shows planar image after 45 minutes with 45° RAO detector rotation. The right figure shows the two time activity curves of the first 10 minutes after tracer application.

trast agents with partial hepatocyte-mediated elimination approved in Germany. 3–5% of Gd-BOPTA is absorbed by the liver, while up to approx. 50% of Gd-EOB is absorbed in healthy subjects. The rest is eliminated by the kidneys. Due to the low hepatic absorption, Gd-BOPTA has not been able to become a relevant imaging-based liver function test [13, 39].

Like mebrofenin, Gd-EOB is absorbed by the hepatocytes via organic anion-transporting polypeptides (OATP) 1B1 and 1B3 and is then eliminated in bile via multidrug resistance protein (MRP) 2 [39–42]. Therefore, its use as an imaging-based liver function test analogous to ^{99m}Tc -mebrofenin scintigraphy is obvious, especially since MRI allows dynamic three-dimensional measurement without ionizing radiation.

Two basic approaches have been described to date. The first approach measures the biliary signal intensity, e.g. in the common bile duct, in the elimination phase. This correlates with the biliary elimination rate of Gd-EOB and thus the liver function. However, biliary outflow problems result in incorrect measurements [43–45].

The second approach is based on the measurement or evaluation of the parenchymal contrast agent behavior over time. The relative enhancement of the liver parenchyma can be determined by ROI analysis. A correlation with the function and prognosis of a liver transplant could be shown for this simple approach. Wibmer et al. examined the relative enhancement of the liver in Gd-EOB-enhanced MRI in 51 liver transplant patients. The relative enhancement correlated directly with the retransplantation-free survival rate [46]. Based on experiments in rats [47, 48], Tajama et al. were one of the first to be able to show the connection between reduced Gd-EOB enhancement and limited liver function in humans. Different lab values, the Child-Pugh score and the ICG test were correlated with the SNR of the liver for this purpose [49]. Various methods for optimizing this method were subsequently published including a correction with the calculation of the liver-to-muscle enhancement ratio [50] and correction based on the liver volume and the enhancement of the spleen to determine the "hepatocellular uptake index" (HUI) [50]. The HUI shows a significant correlation with the ICG clearance rate. Because of its ease of use, this method is currently most widely used [13]. It is problematic to select the optimal MRI sequence.

Relaxometry makes it possible to measure absolute relaxation times and thus allows better comparability between different equipment and sequence types. The T1 and T2* re-

laxation times depend on the Gd-EOB concentration. Katsube et al. were able to correctly determine the Child-Pugh stage with this technique [52, 53]. Haimerl et al. showed a correlation with the MELD score. In total, 233 patients were categorized in three groups according to MELD score. The percentage T1 reduction rate was 59% for a MELD score < 10, 44% for a MELD score of 11–18, and 30% for a MELD score > 18 [54].

The use of dynamic MRI (DCE-MRI) analogously to scintigraphy is the most complicated method since a signal intensity curve must be determined for every voxel of the liver parenchyma with the highest possible temporal resolution. The hepatic extraction fraction can then be calculated for every voxel [55–57]. This method provides excellent correlation with clinical and laboratory parameters [58, 59].

For dynamic data acquisition, sufficiently fast and highly resolved T1-weighted MRI sequences are now available, e.g., the CAIPIRINHI-Dixon-TWIST sequence (controlled aliasing in parallel imaging results in higher acceleration (CAIPIRINHA) time-resolved angiography with stochastic trajectories (TWIST) based on a 3D gradient echo sequence [60]. These 3D gradient echo sequences allow quantification of the T1 relaxation rate change and thus temporal recording of the local contrast agent concentration [61]. They form the technical foundation for hepatobiliary sequence MRI in analogy to hepatobiliary sequence scintigraphy. Due to the high spatial resolution and the minimal motion artifacts as a result of the high temporal resolution, the data can be used for the usual visual evaluation of the signal behavior of focal liver lesions or liver vessels as well as for the functional evaluation. Movement of the liver during individual measurements is problematic for data analysis. With increasing temporal resolution, movements become smaller, but motion correction is still necessary, particularly since the higher temporal resolution allows data acquisition during free breathing. For motion correction, there is currently primarily experience with renal perfusion measurement in MRI [62, 63]. However, motion correction has not yet been used clinically in Gd-EOB-based liver function measurement. Two different motion correction methods are used for the liver: local correction in which only the liver is selectively coregistered with a maximum of 12 degrees of freedom (3x rotation, 3x translation, 3x scaling, 3x shear) or elastic correction of the complete 3D dataset [64, 65].

In addition to the data acquisition obstacles still to be overcome, there are still uncertainties regarding the optimum pharmacokinetic model and the most suitable parameters

for liver function measurement from this model. For evaluating signal-time curves, Nilsson et al. used a model-free approach in which the tissue curve is a convolution of the input curve via a residuum function [56]. The residuum function is calculated by singular value decomposition for which a biexponential approach was selected. The fast exponential function represents the sinusoidal flow in the vascular phase while the slow phase represents the contrast agent retention by the hepatocytes. The use of an exponential residuum function implies identical uptake and elimination rates, see **Fig. 3A**. Therefore, only the first 30 minutes of the measurement are evaluated. This method has two disadvantages: only one input function, the arterial (AIF) or the portal venous (PVIF), which differ greatly, can be taken into consideration; singular value decomposition is very susceptible to noise. The validity of this approach in primary biliary cirrhosis, liver cirrhosis, and primary sclerosing cholangitis was able to be shown [58, 59, 66]. The additional use of the keyhole technique as implemented in the TWIST sequence allows inclusion of the AIF as a result of the higher temporal resolution [65, 67]. Thus, a tissue model (**Fig. 3B**) with two input functions and two compartments can be used which significantly improves the curve adjustment in the sinusoidal wash-in phase and also allows evaluation of liver segments with portal vein embolization [67]. Sourbron et al. measure with high temporal resolution over a total of only 5 minutes so that the contrast agent uptake rate but not the elimination rate can be determined. If the contrast agent dynamics are measured for more than 30 minutes, additional parameters can be determined on the basis of the additionally acquired information: hepatocyte volume and the elimination rate from the hepatocytes, see **Fig. 3C, 4**. However, the increased temporal resolution associated with use of the keyhole technique results in an enormous increase in the amount of data since the complete contrast agent dynamics should be acquired with the same sequence parameters. To reduce the amount of data, data acquisition should be interrupted multiple times after the initial wash-in phase and measurements should be performed discontinuously [65].

In addition to the approach based on Gd-EOB for function measurement, techniques not requiring contrast agent should also be mentioned for the determination of liver parenchyma state. In light of the increasing incidence of non-alcoholic steatohepatitis (NASH), measurement of the degree of fatty infiltration is becoming increasingly important [68]. The quantification of iron content based on the R2 and R2* effects plays an important role in hemochromatosis or hemosiderosis [69]. Fibrosis classification is also increasingly possible due to MR techniques, such as T1 p imaging and MR elastography [70–76]. Diffusion-weighted imaging (DWI) has also already been used for this purpose with advancing sequence technology and application of intravoxel incoherent motion MRI [77–80]. All of these "parenchyma states" can result in cirrhosis and restricted liver function. However, on their own they cannot be used for function measurement. Nonetheless, the signal intensity of Gd-EOB-enhanced MRI is influenced, for example, by the degree of fibrosis as a result of a changed distribution volume of the T1 contrast agent and changed relaxivity in the extracellular space or by the fat or iron content. However, these seem to be negligible due to fast gradient echo

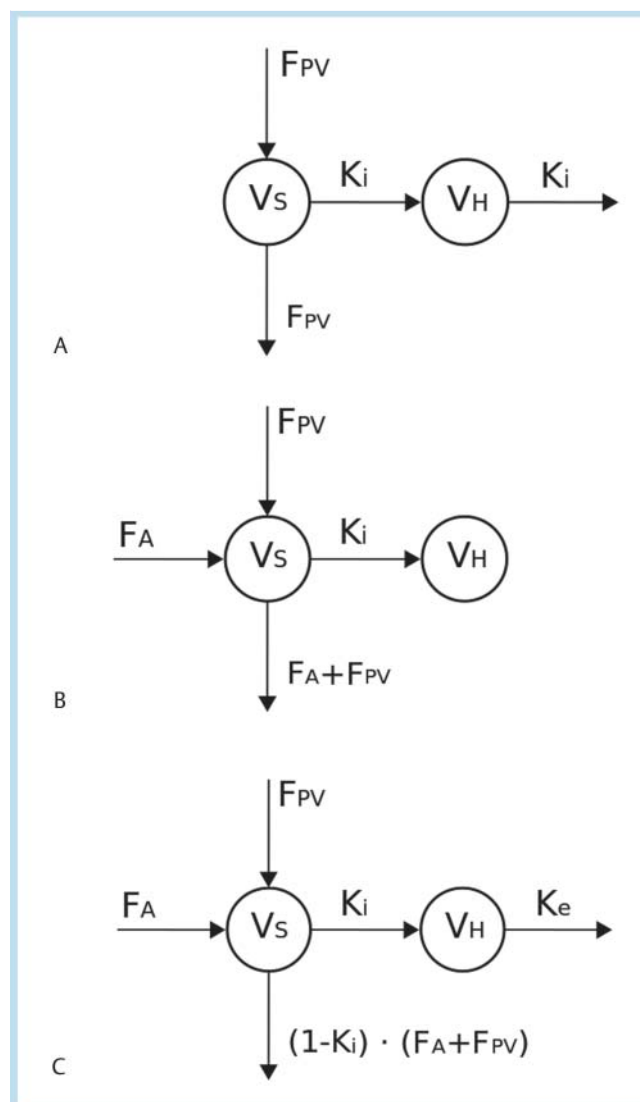

Fig. 3 Published compartment model of **A** Nilsson et al. [56], **B** Sourbron et al. [67], and **C** Zylka et al. [65]. The parameters have the following meanings: F_A : arterial flow, F_{PV} : portal venous flow, v_s : sinusoidal volume; v_H : Hepatocyte volume, K_i : Metabolic rate, K_e : Degradation rate

sequences with short echo times and the use of relative enhancement [51].

Summary and comparison of the methods

A major advantage of Gd-EOB-based tests with respect to clinical workflow and cost is the integration in existing pre-operative imaging. The sequences necessary for function measurement can be integrated in an existing MRI protocol with a moderate increase of the examination time so that in addition to functional information practically all data needed for surgical planning, such as tumor volume and distribution, liver anatomy, vascular supply, and relevant extra-hepatic findings, can be collected in one examination and with a single dose of contrast agent [13].

In nuclear medicine methods, the measurement is performed via a planar gamma camera or SPECT. Therefore, there are limitations with respect to either spatial or tem-

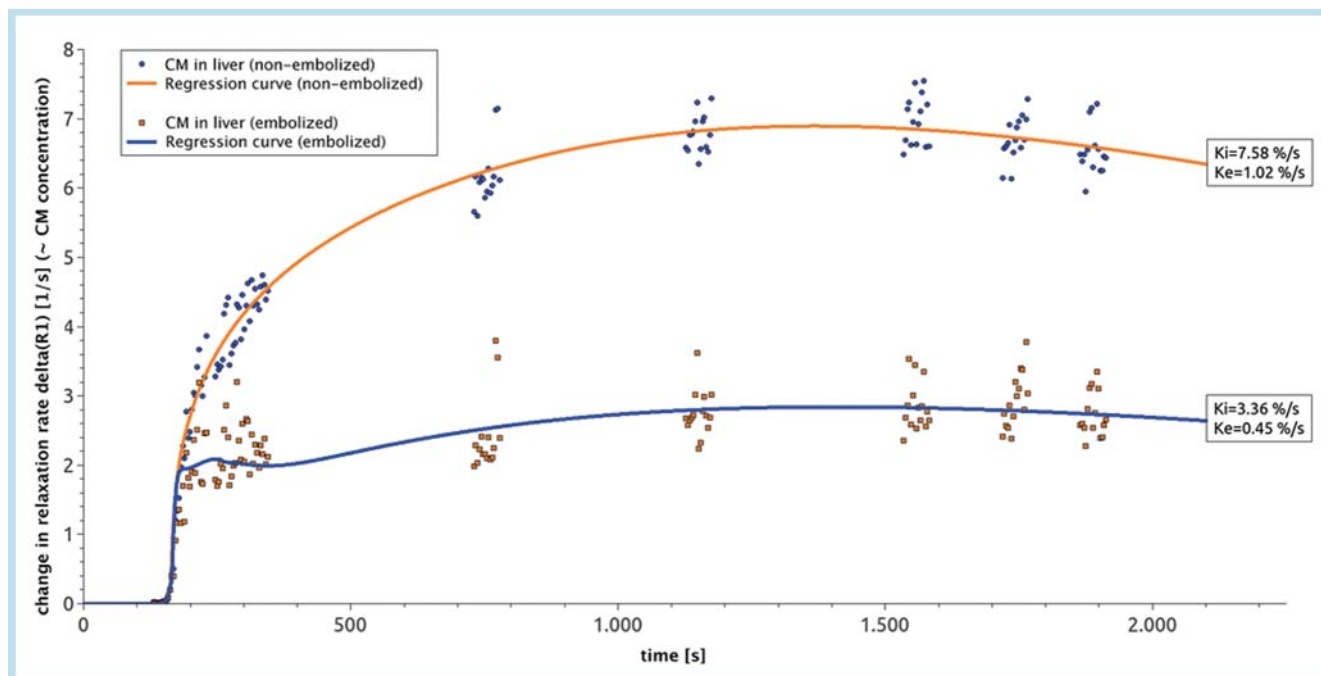

Fig. 4 Spatially averaged curves of the time change of the T1 relaxation rate in a patient with a liver segment with partial occlusion of the portal vein. The continuous lines represent a curve adjustment with the model in

Fig. 3C. The portal venous flow in a liver segment with occlusion of the portal vein was set to zero.

poral resolution. To achieve a temporal and spatial resolution comparable to that of MRI with hepatobiliary sequence scintigraphy, the SPECT acquisition must be significantly accelerated [81]. In contrast, MRI allows acquisition of a 3D dataset of the entire liver within 2–3 seconds with good spatial resolution of $1.2 \times 1.2 \times 3$ mm [60]. High spatial and temporal resolution is necessary for the use of a multi-compartment model since the input function can only be determined from the portal vein and liver artery in this way. A further disadvantage of nuclear medicine techniques is the necessary and complicated attenuation correction and the resulting signal inhomogeneity [82]. An advantage of nuclear medicine techniques is the lack of a background signal.

A further advantage of radiological methods is the elimination of a radioactive tracer and the resulting lack of radiation exposure as well as the simplified usage. According to the guidelines of the Society of Nuclear Medicine (SNM), the effective whole body dose for an applied activity of 175 MBq ^{99m}Tc -mebrofenin is approx. 3 mSv. However, the local dose at the gallbladder can be up to 19 Gy.

The end point for all methods is a correlation with the post-operative liver function after liver resection, i. e., an exact as possible prediction of postoperative function and post-operative liver failure from preoperative functional imaging. A correlation with mortality and postoperative liver failure is currently only ensured for the laboratory liver function test [5, 83]. According to individual studies, post-operative function can also be predicted with ^{99m}Tc -mebrofenin scintigraphy [29]. If this requirement is met, Gd-EOB-enhanced MRI alone can generate all necessary information prior to liver resection.

Outlook



A question that still needs to be clarified relates to the influence of the serum bilirubin level. Bilirubin shares a metabolic pathway with Gd-EOB, IDA analogs, and ICG. As a result, high serum concentrations can result in competitive inhibition causing reduced uptake in the hepatocytes [84]. The influence of renal insufficiency also still needs to be clarified. In the case of healthy renal function, the ratio of renal to hepatic elimination of Gd-EOB is approx. 50:50. However, there is no data regarding the ratio in the case of restricted renal function. Due to the different means of elimination, it remains to be determined whether an imaging-based liver function test is suitable for determining absolute liver function or whether it can only indicate relative function distribution and must therefore be combined with a global test.

In addition to the described use in liver surgery, additional fields of application for imaging-based liver function tests are conceivable. One possibility is dose determination prior to radioembolization (Selective Internal Radiation Therapy, SIRT). Microspheres loaded with yttrium-90 are applied via the liver artery [85, 86]. Due to the predominantly arterial blood supply of liver neoplasias, the β -radiation results in tumor cell reduction. However, restricted liver function due to irradiation also of the healthy liver tissue is often a limitation and can result in postinterventional liver failure [87, 88]. Liver function is currently not included in dose determination. Only limit values for typical lab values such as the serum bilirubin level are taken into consideration. Moreover, to protect the healthy liver parenchyma, radioembolization is often performed on one side, i. e., only in the region of the left or right liver artery [89]. A regional liver function measurement could therefore be included in do-

simetry particularly since Gd-EOB enhanced MRI is already often included in the routine protocol.

A further field of application is diffuse liver diseases, such as primary biliary cirrhosis or primary sclerosing cholangitis, which primarily affect bile ducts but can result in secondary (sub-)segmental restricted hepatic function [90]. An imaging-based liver function test could be used both for early detection and for treatment monitoring. Global function is often not yet limited in the early stage. However, zones of reduced function may be able to be detected by a regional liver function test. Controlling of targeted biopsies from representative liver segments or of segmental biliary decompression measures is conceivable. Initial results indicate high sensitivity of Gd-EOB-enhanced MRI [58, 59, 91, 92]. Detection of the most affected area could be beneficial for planning a diagnostic liver biopsy.

Conclusion

Although it is a relatively new method – Gd-EOB as an MRI contrast agent was first approved in 2004 in Germany – major advancements for using an imaging-based liver function test have been made in recent years. The numerous advantages described here, such as integration in routine diagnostics and the associated cost neutrality, will open new application fields for functional Gd-EOB-enhanced MRI in both hepatology and liver surgery.

Literatur

- Schneider PD. Preoperative assessment of liver function. *Surg Clin North Am* 2004; 84: 355–373
- Sakka SG. Assessing liver function. *Curr Opin Crit Care* 2007; 13: 207–214
- Kanzler S, Teufel A, Galle PR. Liver function test to predict hepatic failure after liver resection – expensive and without clinical relevance? *Zentralbl Chir* 2007; 132: 267–273
- Shirabe K, Shimada M, Gion T et al. Postoperative liver failure after major hepatic resection for hepatocellular carcinoma in the modern era with special reference to remnant liver volume. *J Am Coll Surg* 1999; 188: 304–309
- Seyama Y, Kokudo N. Assessment of liver function for safe hepatic resection. *Hepatology* 2009; 39: 107–116
- Neuhaus P, Jonas S, Settmacher U et al. Surgical management of proximal bile duct cancer: Extended right lobe resection increases resectability and radicality. *Langenbecks Arch Surg* 2003; 388: 194–200
- Neuhaus P, Thelen A, Jonas S et al. Oncological superiority of hilar en bloc resection for the treatment of hilar cholangiocarcinoma. *Ann Surg Oncol* 2012; 19: 1602–1608
- Hemming AW, Reed AI, Howard RJ et al. Preoperative portal vein embolization for extended hepatectomy. *Ann Surg* 2003; 237: 686–691 discussion 691–693
- de Graaf W, van den Esschert JW, van Lienden KP et al. Induction of tumor growth after preoperative portal vein embolization: Is it a real problem? *Ann Surg Oncol* 2009; 16: 423–430
- Schnitzbauer AA, Lang SA, Goessmann H et al. Right portal vein ligation combined with in situ splitting induces rapid left lateral liver lobe hypertrophy enabling 2-staged extended right hepatic resection in small-for-size settings. *Ann Surg* 2012; 255: 405–414
- Avritscher R, de Baere T, Murthy R et al. Percutaneous transhepatic portal vein embolization: Rationale, technique, and outcomes. *Semin Intervent Radiol* 2008; 25: 132–145
- de Graaf W, van Lienden KP, van den Esschert JW et al. Increase in future remnant liver function after preoperative portal vein embolization. *Br J Surg* 2011; 98: 825–834
- Bae KE, Kim SY, Lee SS et al. Assessment of hepatic function with gd-eob-dtpa-enhanced hepatic MRI. *Dig Dis* 2012; 30: 617–622
- de Graaf W, Bemmink RJ, Veteläinen R et al. Nuclear imaging techniques for the assessment of hepatic function in liver surgery and transplantation. *J Nucl Med* 2010; 51: 742–752
- Serafini AN, Smoak WM, Hupf HB et al. Iodine-123-Rose bengal: An improved hepatobiliary imaging agent. *J Nucl Med* 1975; 16: 629–632
- Bennink RJ, Tulchinsky M, de Graaf W et al. Liver function testing with nuclear medicine techniques is coming of age. *Semin Nucl Med* 2012; 42: 124–137
- Akaki S, Mitsumori A, Kanazawa S et al. Technetium-99m-DTPA-galactosyl human serum albumin liver scintigraphy evaluation of regional CT/MRI attenuation/signal intensity differences. *J Nucl Med* 1998; 39: 529–532
- Vera DR, Krohn KA, Stadalnik RC et al. Tc-99m-galactosyl-neoglycoalbumin: In vivo characterization of receptor-mediated binding to hepatocytes. *Radiology* 1984; 151: 191–196
- Kokudo N, Vera DR, Makuuchi M. Clinical application of tcgsa. *Nucl Med Biol* 2003; 30: 845–849
- Loberg MD, Cooper M, Harvey E et al. Development of new radiopharmaceuticals based on n-substitution of iminodiacetic acid. *J Nucl Med* 1976; 17: 633–638
- de Graaf W, Häusler S, Heger M et al. Transporters involved in the hepatic uptake of (99m)tc-mebrofenin and indocyanine green. *J Hepatol* 2011; 54: 738–745
- Hendrikse NH, Kuipers F, Meijer C et al. In vivo imaging of hepatobiliary transport function mediated by multidrug resistance associated protein and p-glycoprotein. *Cancer Chemother Pharmacol* 2004; 54: 131–138
- Ghibellini G, Leslie EM, Pollack GM et al. Use of tc-99m mebrofenin as a clinical probe to assess altered hepatobiliary transport: Integration of in vitro, pharmacokinetic modeling, and simulation studies. *Pharm Res* 2008; 25: 1851–1860
- Krishnamurthy S, Krishnamurthy GT. Technetium-99m-iminodiacetic acid organic anions: Review of biokinetics and clinical application in hepatology. *Hepatology* 1989; 9: 139–153
- Krishnamurthy GT, Turner FE. Pharmacokinetics and clinical application of technetium 99m-labeled hepatobiliary agents. *Semin Nucl Med* 1990; 20: 130–149
- de Graaf W, van Lienden KP, van Gulik TM et al. (99m)tc-mebrofenin hepatobiliary scintigraphy with SPECT for the assessment of hepatic function and liver functional volume before partial hepatectomy. *J Nucl Med* 2010; 51: 229–236
- Brown PH, Juni JE, Lieberman DA et al. Hepatocyte versus biliary disease: A distinction by deconvolutional analysis of technetium-99m IDA time-activity curves. *J Nucl Med* 1988; 29: 623–630
- Erdogan D, Heijnen BH, Bennink RJ et al. Preoperative assessment of liver function: A comparison of 99mTc-mebrofenin scintigraphy with indocyanine green clearance test. *Liver Int* 2004; 24: 117–123
- Bennink RJ, Dinant S, Erdogan D et al. Preoperative assessment of post-operative remnant liver function using hepatobiliary scintigraphy. *J Nucl Med* 2004; 45: 965–971
- van Lienden KP, van den Esschert JW, de Graaf W et al. Portal vein embolization before liver resection: A systematic review. *Cardiovasc Intervent Radiol* 2012; 36: 25–34
- Yumoto Y, Yagi T, Sato S et al. Preoperative estimation of remnant hepatic function using fusion images obtained by (99m)tc-labelled galactosyl-human serum albumin liver scintigraphy and computed tomography. *Br J Surg* 2010; 97: 934–944
- Hirai I, Kimura W, Fuse A et al. Evaluation of preoperative portal embolization for safe hepatectomy, with special reference to assessment of nonembolized lobe function with 99mTc-gsa SPECT scintigraphy. *Surgery* 2003; 133: 495–506
- Sumiyoshi T, Shima Y, Tokorodani R et al. CT/99mTc-gsa SPECT fusion images demonstrate functional differences between the liver lobes. *World J Gastroenterol* 2013; 19: 3217–3225
- Sumiyoshi T, Shima Y, Okabayashi T et al. Functional discrepancy between two liver lobes after hemilobe biliary drainage in patients with jaundice and bile duct cancer: An appraisal using (99m)Tc-gsa SPECT/CT fusion imaging. *Radiology* 2014; 273: 444–451
- Beppu T, Hayashi H, Okabe H et al. Liver functional volumetry for portal vein embolization using a newly developed 99mTc-galactosyl human serum albumin scintigraphy spect-computed tomography fusion system. *J Gastroenterol* 2011; 46: 938–943
- Kaibori M, Ha-Kawa SK, Maehara M et al. Usefulness of tc-99m-gsa scintigraphy for liver surgery. *Ann Nucl Med* 2011; 25: 593–602

- 37 Ringe KI, Husarik DB, Sirlin CB et al. Gadaxetate disodium-enhanced MRI of the liver: Part 1, protocol optimization and lesion appearance in the noncirrhotic liver. *Am J Roentgenol* 2010; 195: 13–28
- 38 Cruite I, Schroeder M, Merkle EM et al. Gadaxetate disodium-enhanced MRI of the liver: Part 2, protocol optimization and lesion appearance in the cirrhotic liver. *Am J Roentgenol* 2010; 195: 29–41
- 39 Hamm B, Staks T, Mühler A et al. Phase I clinical evaluation of gd-eob-dtpa as a hepatobiliary MR contrast agent: Safety, pharmacokinetics, and MR imaging. *Radiology* 1995; 195: 785–792
- 40 Van Beers BE, Pastor CM, Hussain HK. Primovist, eovist: What to expect? *J Hepatol* 2012; 57: 421–429
- 41 Narita M, Hatano E, Arizono S et al. Expression of OATP1B3 determines uptake of gd-eob-dtpa in hepatocellular carcinoma. *J Gastroenterol* 2009; 44: 793–798
- 42 Pascolo L, Cupelli F, Anelli PL et al. Molecular mechanisms for the hepatic uptake of magnetic resonance imaging contrast agents. *Biochem Biophys Res Commun* 1999; 257: 746–752
- 43 Takao H, Akai H, Tajima T et al. MR imaging of the biliary tract with gd-eob-dtpa: Effect of liver function on signal intensity. *Eur J Radiol* 2011; 77: 325–329
- 44 Smith AD, Veniero JC. Gd-EOB-DTPA as a functional MR cholangiography contrast agent: Imaging gallbladder filling in patients with and without hepatobiliary dysfunction. *J Comput Assist Tomogr* 2011; 35: 439–445
- 45 Lee NK, Kim S, Lee JW et al. Biliary MR imaging with gd-eob-dtpa and its clinical applications. *Radiographics* 2009; 29: 1707–1724
- 46 Wibmer A, Aliya Q, Steininger R et al. Liver transplantation: Impaired biliary excretion of gadaxetate is associated with an inferior 1-year retransplantation-free survival. *Invest Radiol* 2012; 47: 353–358
- 47 Schmitz SA, Mühler A, Wagner S et al. Functional hepatobiliary imaging with gadolinium-eob-dtpa. A comparison of magnetic resonance imaging and ¹⁵³gadolinium-eob-dtpa scintigraphy in rats. *Invest Radiol* 1996; 31: 154–160
- 48 Kim T, Murakami T, Hasuiki Y et al. Experimental hepatic dysfunction: Evaluation by MRI with gd-eob-dtpa. *J Magn Reson Imaging* 1997; 7: 683–688
- 49 Tajima T, Takao H, Akai H et al. Relationship between liver function and liver signal intensity in hepatobiliary phase of gadolinium ethoxybenzyl diethylenetriamine pentaacetic acid-enhanced magnetic resonance imaging. *J Comput Assist Tomogr* 2010; 34: 362–366
- 50 Motosugi U, Ichikawa T, Oguri M et al. Staging liver fibrosis by using liver-enhancement ratio of gadaxetate acid-enhanced MR imaging: Comparison with aspartate aminotransferase-to-platelet ratio index. *Magn Reson Imaging* 2011; 29: 1047–1052
- 51 Yamada A, Hara T, Li F et al. Quantitative evaluation of liver function with use of gadaxetate disodium-enhanced MR imaging. *Radiology* 2011; 260: 727–733
- 52 Katsube T, Okada M, Kumano S et al. Estimation of liver function using T1 mapping on gd-eob-dtpa-enhanced magnetic resonance imaging. *Invest Radiol* 2011; 46: 277–283
- 53 Katsube T, Okada M, Kumano S et al. Estimation of liver function using T2* mapping on gadolinium ethoxybenzyl diethylenetriamine pentaacetic acid enhanced magnetic resonance imaging. *Eur J Radiol* 2012; 81: 1460–1464
- 54 Haimerl M, Verloh N, Fellner C et al. MRI-based estimation of liver function: Gd-EOB-DTPA-enhanced T1 relaxometry of 3T vs. The MELD score. *Sci Rep* 2014; 4: 5621
- 55 Sommer WH, Sourbron S, Huppertz A et al. Contrast agents as a biological marker in magnetic resonance imaging of the liver: Conventional and new approaches. *Abdom Imaging* 2012; 37: 164–179
- 56 Nilsson H, Nordell A, Vargas R et al. Assessment of hepatic extraction fraction and input relative blood flow using dynamic hepatocyte-specific contrast-enhanced MRI. *J Magn Reson Imaging* 2009; 29: 1323–1331
- 57 Forsgren MF, Dahlqvist Leinhard O, Dahlström N et al. Physiologically realistic and validated mathematical liver model reveals hepatobiliary transfer rates for gd-eob-dtpa using human DCE-MRI data. *PLoS One* 2014; 9: e95700
- 58 Nilsson H, Blomqvist L, Douglas L et al. Dynamic gadaxetate-enhanced MRI for the assessment of total and segmental liver function and volume in primary sclerosing cholangitis. *J Magn Reson Imaging* 2014; 39: 879–886
- 59 Nilsson H, Blomqvist L, Douglas L et al. Assessment of liver function in primary biliary cirrhosis using gd-eob-dtpa-enhanced liver MRI. *HPB (Oxford)* 2010; 12: 567–576
- 60 Michaely HJ, Morelli JN, Budjan J et al. CAIPIRINHA-Dixon-TWIST (CDT)-volume-interpolated breath-hold examination (VIBE): A new technique for fast time-resolved dynamic 3-dimensional imaging of the abdomen with high spatial resolution. *Invest Radiol* 2013; 48: 590–597
- 61 Li KL, Zhu XP, Waterton J et al. Improved 3D quantitative mapping of blood volume and endothelial permeability in brain tumors. *J Magn Reson Imaging* 2000; 12: 347–357
- 62 Hamy V, Dikaïos N, Punwani S et al. Respiratory motion correction in dynamic MRI using robust data decomposition registration – application to DCE-MRI. *Med Image Anal* 2014; 18: 301–313
- 63 Lin W, Guo J, Rosen MA et al. Respiratory motion-compensated radial dynamic contrast-enhanced (DCE)-MRI of chest and abdominal lesions. *Magn Reson Med* 2008; 60: 1135–1146
- 64 Wybranski C, Seidensticker M, Mohnike K et al. In vivo assessment of dose volume and dose gradient effects on the tolerance dose of small liver volumes after single-fraction high-dose-rate 192Ir irradiation. *Radiat Res* 2009; 172: 598–606
- 65 Zylka P, Denecke T, Geisel D et al. Pharmacokinetic modeling and quantification of the liver function using DCE-MRI with contrast agent gd-eob-dtpa. *Joint Conference of the SSRMP, DGMP, ÖGMP* 2014; 128: 236–237
- 66 Nilsson H, Blomqvist L, Douglas L et al. Gd-EOB-DTPA-enhanced MRI for the assessment of liver function and volume in liver cirrhosis. *Br J Radiol* 2013; 86: 20120653
- 67 Sourbron S, Sommer WH, Reiser MF et al. Combined quantification of liver perfusion and function with dynamic gadaxetate acid-enhanced MR imaging. *Radiology* 2012; 263: 874–883
- 68 Reeder SB, Cruite I, Hamilton G et al. Quantitative assessment of liver fat with magnetic resonance imaging and spectroscopy. *J Magn Reson Imaging* 2011; 34: 729–749
- 69 Hernando D, Levin YS, Sirlin CB et al. Quantification of liver iron with MRI: State of the art and remaining challenges. *J Magn Reson Imaging* 2014; 40: 1003–1021
- 70 Bonekamp S, Kamel I, Solga S et al. Can imaging modalities diagnose and stage hepatic fibrosis and cirrhosis accurately? *J Hepatol* 2009; 50: 17–35
- 71 Salameh N, Larrat B, Abarca-Quinones J et al. Early detection of steatohepatitis in fatty rat liver by using MR elastography. *Radiology* 2009; 253: 90–97
- 72 Allkemper T, Sagmeister F, Cicinnati V et al. Evaluation of fibrotic liver disease with whole-liver t1p MR imaging: A feasibility study at 1.5 T. *Radiology* 2014; 271: 408–415
- 73 Rauscher I, Eiber M, Ganter C et al. Evaluation of t1p as a potential MR biomarker for liver cirrhosis: Comparison of healthy control subjects and patients with liver cirrhosis. *Eur J Radiol* 2014; 83: 900–904
- 74 Faria SC, Ganesan K, Mwangi I et al. MR imaging of liver fibrosis: Current state of the art. *Radiographics* 2009; 29: 1615–1635
- 75 Wang YX, Yuan J, Chu ES et al. T1rho MR imaging is sensitive to evaluate liver fibrosis: An experimental study in a rat biliary duct ligation model. *Radiology* 2011; 259: 712–719
- 76 Asbach P, Klatt D, Schlosser B et al. Viscoelasticity-based staging of hepatic fibrosis with multifrequency MR elastography. *Radiology* 2010; 257: 80–86
- 77 Ding Y, Rao S, Chen C et al. Assessing liver function in patients with hbv-related HCC: A comparison of T1 mapping on gd-eob-dtpa-enhanced MR imaging with DWI. *Eur Radiol* 2015; 25: 1392–1398
- 78 Bülow R, Mensel B, Meffert P et al. Diffusion-weighted magnetic resonance imaging for staging liver fibrosis is less reliable in the presence of fat and iron. *Eur Radiol* 2013; 23: 1281–1287
- 79 Chung SR, Lee SS, Kim N et al. Intravoxel incoherent motion MRI for liver fibrosis assessment: A pilot study. *Acta Radiol* 2014; DOI: 10.1177/0284185114559763
- 80 Ichikawa S, Motosugi U, Morisaka H et al. MRI-based staging of hepatic fibrosis: Comparison of intravoxel incoherent motion diffusion-weighted imaging with magnetic resonance elastography. *J Magn Reson Imaging* 2014; 42: 204–210
- 81 Winant CD, Aparici CM, Zelnik YR et al. Investigation of dynamic SPECT measurements of the arterial input function in human subjects using simulation, phantom and human studies. *Phys Med Biol* 2012; 57: 375–393
- 82 Kashiwagi T, Yutani K, Fukuchi M et al. Correction of nonuniform attenuation and image fusion in SPECT imaging by means of separate x-ray CT. *Ann Nucl Med* 2002; 16: 255–261

- 83 Stockmann M, Lock JF, Malinowski M *et al.* The limax test: A new liver function test for predicting postoperative outcome in liver surgery. *HPB (Oxford)* 2010; 12: 139–146
- 84 Lan JA, Chervu LR, Johansen KL *et al.* Uptake of technetium 99m hepatobiliary imaging agents by cultured rat hepatocytes. *Gastroenterology* 1988; 95: 1625–1631
- 85 Salem R, Thurston KG. Radioembolization with 90yttrium microspheres: A state-of-the-art brachytherapy treatment for primary and secondary liver malignancies. Part 1: Technical and methodologic considerations. *J Vasc Interv Radiol* 2006; 17: 1251–1278
- 86 Lewandowski RJ, Sato KT, Atassi B *et al.* Radioembolization with 90Y microspheres: Angiographic and technical considerations. *Cardiovasc Intervent Radiol* 2007; 30: 571–592
- 87 Sangro B, Gil-Alzugaray B, Rodriguez J *et al.* Liver disease induced by radioembolization of liver tumors: Description and possible risk factors. *Cancer* 2008; 112: 1538–1546
- 88 Gil-Alzugaray B, Chopitea A, Iñarrairaegui M *et al.* Prognostic factors and prevention of radioembolization-induced liver disease. *Hepatology* 2012; 57: 1078–1087
- 89 Seidensticker R, Seidensticker M, Damm R *et al.* Hepatic toxicity after radioembolization of the liver using (90)y-microspheres: Sequential lobar versus whole liver approach. *Cardiovasc Intervent Radiol* 2012; 35: 1109–1118
- 90 Hope TA, Ohliger MA, Qayyum A. MR imaging of diffuse liver disease: From technique to diagnosis. *Radiol Clin North Am* 2014; 52: 709–724
- 91 Nolz R, Asenbaum U, Schoder M *et al.* Diagnostic workup of primary sclerosing cholangitis: The benefit of adding gadoxetic acid-enhanced t1-weighted magnetic resonance cholangiography to conventional t2-weighted magnetic resonance cholangiography. *Clin Radiol* 2014; 69: 499–508
- 92 Ruiz A, Lemoine S, Carrat F *et al.* Radiologic course of primary sclerosing cholangitis: Assessment by three-dimensional magnetic resonance cholangiography and predictive features of progression. *Hepatology* 2014; 59: 242–250