

Professor Steven V. Ley CBE FRS at Seventy – The last Fifty Years



Photography 1 A recent picture of Steve and Rose

I am not sure how it happened, but the past fifty years seem to have just flown past. It was early in the autumn term of 1965 that I first met Steven Ley when he came to me during a laboratory class and asked if I would suggest some additional experiments that he could carry out. At that time I had two new research students who were beginning projects involving benzyne chemistry and I thought that we might need some tetraphenylcyclopentadienone (tetracyclone); in addition, I was aware that there was a supply of benzil and dibenzyl ketone in the organic chemistry store. I suggested a visit to the library to find out an experimental procedure and that he might then make a 20 g batch of the black compound. A few grams of tetracyclone could then be used to investigate the reaction with maleic anhydride: interesting because the Diels–Alder reaction can lead to two products depending on how the reaction is carried out and the care taken when heating the co-reactants in the presence or absence of a solvent. I did not reveal that some appropriate experiments could be found in *Organic Syntheses*!

A couple of years after my first meeting with Steve, a young lady came to my room with a group of about three other first year undergraduates for their first organic chemistry tutorial and, because of my connection with Somerset, I commented on her West Country accent: Rosemary later became Steve's wife (Photography 1).

Steve Ley carried out a final year undergraduate research project with me in the spring and summer of 1969 and then asked Professor Gordon Kirby if he could join my group as a research student in October 1969. It was often said that a potential research student or post-doctoral assistant who wished to work either with Gordon or me should be interested in playing cricket because we ran an organic chemistry research group team that played each summer, normally on Wednesday evenings. There were important social sides, illustrated in a number of the photographs shown below, many of them associated with the consumption of liquid refreshments: they compliment the more serious business of research.

Steve began his research by carrying out Diels–Alder reactions of a number of benzenoid and other aromatic substances with tetrahalogenobenzenes for use in a study of rearrangement and other reactions of the products. Some of the compounds that we required were available from earlier work. The first communication¹ was concerned with reactions of 1-*N,N*-dimethylaminotetrahalogenobenzobarrelene derivatives and this work was followed by studies of acid catalyzed rearrangement reactions of a number of 1-methoxybenzobarrelene derivatives. An early interest in newly developed technologies resulted in us having a silica apparatus made that allowed us to study the *in vacuo* pyrolysis of some bridged systems, for example the dihydro derivatives of the adducts obtained from aryne reactions with

6,6-dimethylfulvene. We also reasoned that the 4,5,6,7-tetrahalogenoisobenzofurans and the related *N*-methyl-4,5,6,7-tetrafluoroisindole would be more stable than isobenzofuran and *N*-methylisindole and that they could be accessed indirectly from the Diels–Alder adducts of arynes with furan and *N*-methylpyrrole respectively using the retro-Diels–Alder reactions of their dihydro derivatives, in the case of the isobenzofurans using the flash vacuum pyrolysis apparatus.²

Steve made sure that he was aware of other topics that were being investigated in the Loughborough laboratories and in one of our discussions he mentioned that flavothebaone and its trimethyl ether and the origin of the colour was the topic of an undergraduate project being carried out by one of Gordon Kirby's students. We decided that we had a route to a suitable model compound that would allow us to investigate the reason for the bathochromic shift in the ultraviolet spectrum of the α,β -unsaturated ketone chromophore that was present in flavothebaone trimethyl ether. Flavothebaone had been isolated in 1938 by Schöpf and although the structure of its trimethyl ether was elucidated in 1957, a model compound suitable for the study if its ultraviolet spectrum had not been reported. Our synthesis of a model compound (Scheme 1) depended on the electron-withdrawing inductive effects of the two methoxy groups present in 3,6-dimethoxybenzyne making the aryne sufficiently electrophilic that it would undergo a Diels–Alder reaction with veratrole: the aryne precursor 2-amino-3,6-dimethoxybenzoic acid would be made starting from 3,6-dimethoxybenzamide. We waited until the undergraduate projects had finished and then discussed this proposal with Gordon. Most of the experimental work was carried out in the summer of 1972, towards the end of Steve's period as a research student, and the study was published soon after.³

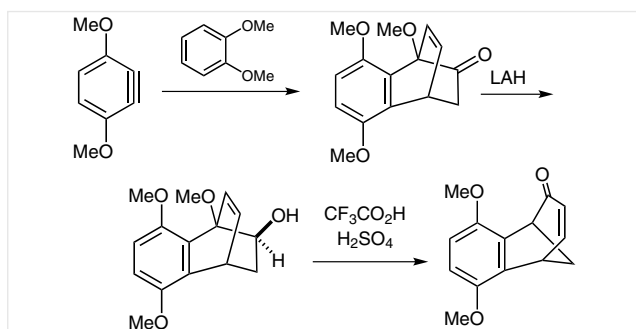

Scheme 1 The synthesis of a model for flavothebaone trimethyl ether

The most cited paper that came from this period of Steve's work involved the *N*-alkylation of indole and pyrroles in dimethyl sulfoxide:⁴ it is still being cited in 2015. Sixteen publications resulted from the period when Steve was a PhD student, and during the early months of 1972 Steve wrote to a number of the most respected organic chemists in the USA about potential postdoctoral positions.

I particularly remember the letter that I received from Leo Paquette in which he asked me to evaluate Steve's contribution to our published work: Steve, Rose, and their young daughter then moved to Ohio State University (OSU) in Columbus to join a thriving and prestigious group where Steve was able to make valuable contributions to a number of projects (Photography 2).

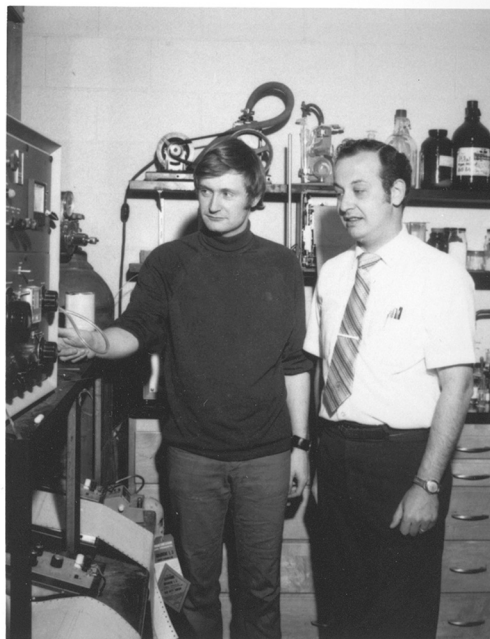

Photography 2 Steve with Leo in about 1973

The two years at OSU were equally productive and resulted in eleven publications. An early paper was concerned with the synthesis of (–)-triquinacene-2-carboxylic acid (Figure 1, a)⁵ and I believe it was at OSU that Steve developed an interest in the chemistry of alkene metal carbonyl complexes, (Figure 1, b). Leo Paquette invited me to visit the department in the summer of 1973, and he was clearly determined that Steve should not return to the UK other than by going to one of the best departments of chemistry. He told me, with much pleasure, how Steve had devised an apparatus for the preparation of high purity liquid ²H₃-ammonia for use in alkali metal reductions. The reduction of *cis*- and *trans*-bicyclo[6.1.0]nona-2,4,6-trienes in deuterated liquid ammonia was published as a full paper with just two authors.⁶ It is also interesting to note how an earlier use of a reagent can lead to its use again at a much later date: the use of magnesium nitride as a source of ammonia in the Paal–Knorr preparation of pyrroles⁷ and in the preparation of primary amides from esters⁸ being examples. Before I left OSU to go on to other places Leo asked me to write to Sir Derek Barton when I returned to the UK as well as asking

Gordon Kirby to write too. I received a reply in the form of the usual two-sentence letter from Sir Derek which can be summarised as “We will be pleased to look at Dr. Ley!”

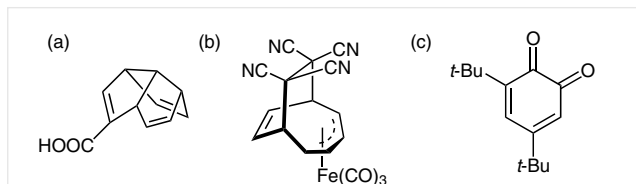

Figure 1

So Steve returned from the USA in 1974 to work with Sir Derek in a post-doctoral position at Imperial College (Photography 3), initially working on the chemistry of organoselenium compounds. The first of the 29 papers that were published as a member of the Barton group involved the oxidation of phenols to ortho-quinones (Figure 1, c), using diphenylseleninic anhydride as the oxidizing agent.⁹ Research using diphenylseleninic anhydride continued from time to time for a number of years, and the last publications with the Barton group were concerned with the oxidation at benzylic positions, for example *o*-xylene to *o*-tolualdehyde.¹⁰



Photography 3 Steve with Sir Derek H. R. Barton and other members of the group in the mid-70s

Steve was appointed to a lectureship in 1975 and began to develop his own areas of research, but he continued to work with the Barton group for several years, for example on tetracycline synthesis.¹¹ He was appointed to a chair in the department in 1983 and was elected as a Fellow of The Royal Society in 1990. Some examples of social activities associated with Steve and his research group are shown in the photographs, most of them involve liquids! I attended two parties at IC that were held in 1983 and 1990 and I remember that champagne flowed freely and that on the second occasion Steve banged two champagne bottles together in order to be able to speak. Two Champagne bottles reap-

peared at a 60th birthday celebration and more recently, as seen in one of the photographs, the champagne bottles have been replaced by a bottle of water (Photography 4).



Visit Young's Pubs in the early 1980s

More recently – ready to speak!

Photography 4

Now with over eight hundred publications any selection for mention must be a very personal one and so I will choose to exemplify the more important areas of Steve's work, as I see them. The areas of study that I will highlight are: the total synthesis of natural products, the introduction of new reagents, for example tetrapropylammonium perruthenate (TPAP),^{12,13} the use of novel protecting groups, and the use of new technologies, noting particularly the more recent development and use of flow systems. A long series of important papers is concerned with the use of 1,2-diacetals in synthesis, for example in the regioselective protection of sugars,¹⁴ and reviewed in a perspective.¹⁵ One of the first papers published by Steve as an independent researcher involved the formation of dienes using iron carbonyl complexes,¹⁶ and further work in the same area has been reported from time to time; including the synthesis of β -lactams using tricarbonyl iron lactone complexes,¹⁷ and the antibiotic (+)-thienamycin.¹⁸ The synthesis of natural products soon became one of the key sectors in the work of the Ley group and an early example was of the ionophore antibiotic X-14547A.¹⁹ The synthesis of both (+)-pinitol (Figure 2) and its enantiomer²⁰ was achieved by making use of the microbial oxidation of benzene to *cis*-1,2-dihydroxycyclohexadiene. The total synthesis of (+)-milbemycin²¹ (Figure 3, a) was the first of the syntheses of macrocyclic compounds completed by the Ley group, with its structure also shown on the front of the 'Whiffen Cowboys 40' jumper (Photography 5), and the synthesis of indanomycin was also undertaken (Figure 3, b).²² An interest in insect anti-feedant compounds was revealed in an early part of Steve's career, for example in the synthesis of a number of decalin derivatives²³ and clerodane diterpenoids such as ajugarin I (Figure 3, c).²⁴ Among the simpler natural products synthesized is the alkaloid ruspolinone.²⁵

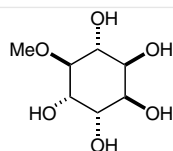

Figure 2

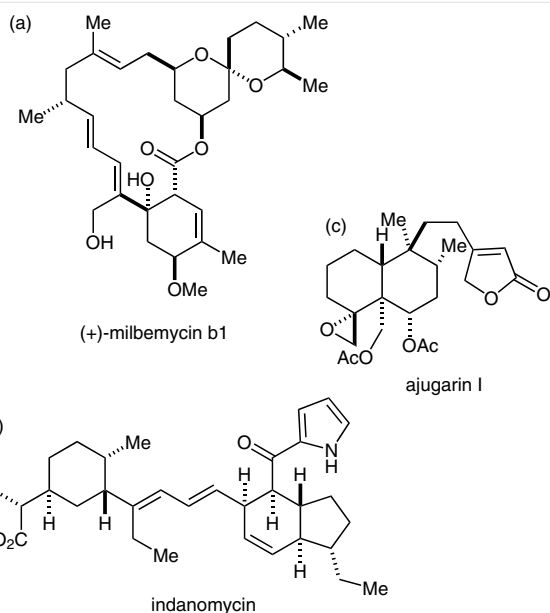

Figure 3

Save for an interregnum during World War II, there has been a Chair of Chemistry at Cambridge University continuously since 1702. The Grace of Senate at Cambridge that established a chair of chemistry for Vigani, a friend of Isaac Newton, is dated February 10th 1702. However, unlike many European roman catholic countries, Britain was still using the Julian calendar rather than the Gregorian calendar that had been established by papal bull in 1582. The problem with the Julian calendar was related to the date of the vernal equinox that was used, following the council of Nicea in in AD 325, to establish the date of the Christian Easter festi-

val. The Julian year cycle used a value of 365.25 days rather than the more accurate value of 365.2425 days. Thus, by 1582 the date of the vernal equinox had moved from March 21st to March 11th and by 1752, when Britain began to use the Gregorian calendar, to March 10th. So is a date of February 21st 1702 more appropriate for the date of the establishment of the chair? It is interesting to note that Greece only adopted the Gregorian Calendar in 1923 and Turkey on January 1st 1927.

The fifth holder of the chair of chemistry at Cambridge, Richard Watson, who only held the position from 1764 to 1771, provides an amusing commentary that illustrates an early step in the transformation of the importance of chemistry as an academic discipline. There was no stipend associated with the chair of chemistry and therefore no competition for the position and, as Watson had indicated an interest, he was duly elected. However, he then asked the Chancellor of the University for help and eventually obtained a stipend of £100 per annum from government sources. Following the death of the Regius Professor of Divinity, whose stipend was initially £330 per annum, Watson undertook the steps that were required to obtain the degree of Doctor of Divinity and so was duly elected as Professor of Divinity. But the story does not end there: in 1782 Watson was appointed as Bishop of Llandaff! During the Napoleonic wars the gunpowder used by the British navy was initially inferior to that used by the French and the head of the British Ordnance Department asked the Bishop of Llandaff for help. Watson identified that the problem related to the method used for the preparation of charcoal, and his suggested changes resulted in significant improvement in the efficacy of the gunpowder used by the British navy.

There have been a number of important holders of the Chair of Chemistry during the past three hundred years. Most of the readers of this introduction will either have met or read papers written by holders of the twelfth to the fifteenth holders. However, it is worth pointing out that W. J. Pope, who had been appointed to the chair of chemistry in 1908, and who died in office in 1939, did much to improve the chemistry department laboratories in Cambridge, and



Photography 5 Steve's 40th Birthday, 4 years before the total synthesis of (+)-milbemycin

as a result, many old college laboratories were closed. After an interregnum, because of World War II and various negotiations, Alexander Todd was elected in 1944 and moved from Manchester as Professor of Organic Chemistry at Cambridge, effectively the twelfth holder of the 1702 chair. One of Todd's requirements resulted in the construction of the Lensfield Road laboratories. On the appointment of Alan Battersby to a second Chair of Organic Chemistry, the 1702 Chair of Chemistry at Cambridge was named for Lord Todd in 1970 as the 1702 Chair of Organic Chemistry. The British Petroleum Company re-endowed the 1702 chair in 1990.

Steve moved from Imperial College in 2002 when he was elected as the fifteenth holder of the renamed BP 1702 Professor of Organic Chemistry at Cambridge. Steve celebrated his 50th birthday at Cambridge by which time the Imperial College 'Rock-and-Roll years' had been replaced by what some might define as more mature tastes in music. It is well known that Steve enjoys high fidelity reproduction of music using very high quality equipment and sometimes his neighbours hear it as well! As shown in the photograph (Photography 6) there was a presentation of conductor's batons so that he could conduct opera at home. The 50th birthday was also celebrated a few months later and that involved a trip by his group to Bourg Saint Maurice in France so that they could all ski at 'Le(y)s Arcs'.

It is appropriate that we should now turn to some of the more recent studies that have resulted in total syntheses of natural products, some of which were started at Imperial College and completed in the Cambridge laboratories. Among these, perhaps the most impressive, and certainly the structure that took the longest to bring under full control, was azadirachtin; it proved to be a mammoth undertaking. It had been known for about 2000 years that the evergreen Neem tree (*Azadirachta indica*, Photography 7) did not suffer significant damage from locusts on the Indian subcontinent where it is native. It was imported into a number of Middle East and Sub Saharan African countries:

for example in Sudan, where, during an attack by locusts, Neem trees were the only plants not to be severely damaged.²⁶ Neem trees were imported also into Queensland and The Northern Territory (Australia), to provide shade for animals in arid areas. However, it is interesting that the Neem tree is now regarded as a weed in some areas where it had been introduced. Earlier this year the Neem tree was designated as a class B and C weed by the Department of Land Resource Management in the Northern Territory (Australia). Such a designation means that its growth and spread must be controlled and that seeds and plants may not be imported.



Photography 7 A Neem Tree (adapted from a Wiki commons photograph by Abhijeet)

In 1968, an antifeedant substance was isolated from the seeds of the Neem tree, was named azadirachtin and, after some years, a structure was proposed on the basis of NMR data. The Ley group published a revised structure for azadirachtin (Figure 4, a), based on NMR experiments that were not available earlier,²⁷ together with an X-ray structure determination of a derivative and also its absolute con-



Conducting at a 50th birthday party



60th birthday celebration

Photography 6

figuration.^{28,29} The synthesis of azadirachtin was to become an ongoing area of study and a long series of papers was published, beginning in 1988³⁰ and continuing during a period of over twenty years. Part 22 was published in 1999, and the work culminated in 2007 when a total synthesis was reported in two consecutive papers.³¹

Steve sent me proof copies of the papers and like me, many colleagues around the world must have enjoyed reading them. But that was not the end of the azadirachtin story: a full paper with complete experimental details was published that included the names of all 43 co-workers who had made a contribution,³² as well as the synthesis of five natural products isolated from *Azadirachta indica* from a common intermediate,^{33a} and a second-generation synthesis of azadirachtin.^{33b} An important long review puts the Ley group synthesis alongside the work of other groups that

have contributed to the saga.³⁴ Two recent total syntheses of the immunosuppressant compounds antascomycin (Figure 4, b)³⁵ and (-)-rapamycin^{36,37} (Figure 4, c) also illustrate the complexity involved in the construction of macrocyclic compounds. And the story goes on: for example this year, syntheses of the callipeltosides was reported,³⁸ illustrated by the structure of callipeltoside C (Figure 4, d).

Finally I want to return to the topic of the use of recently established technologies for use in organic synthesis. The areas used by Steve in his researches include most, if not all, of the new methods that have been introduced in the past fifty years: they include ultrasound;³⁹ polymer supported reagents, for example hypervalent iodine reagents for use in combinatorial chemistry;⁴⁰ the synthesis of (\pm)-epibatidine;^{41,42} as well as microwave assisted reactions.⁴³

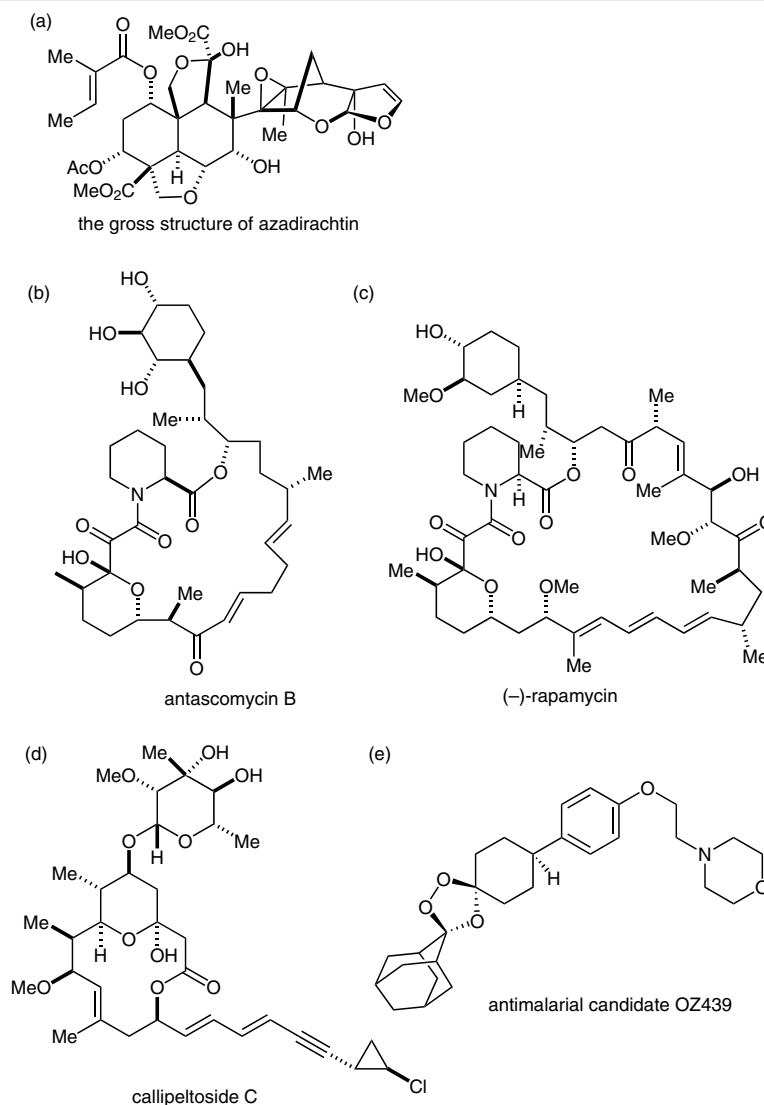
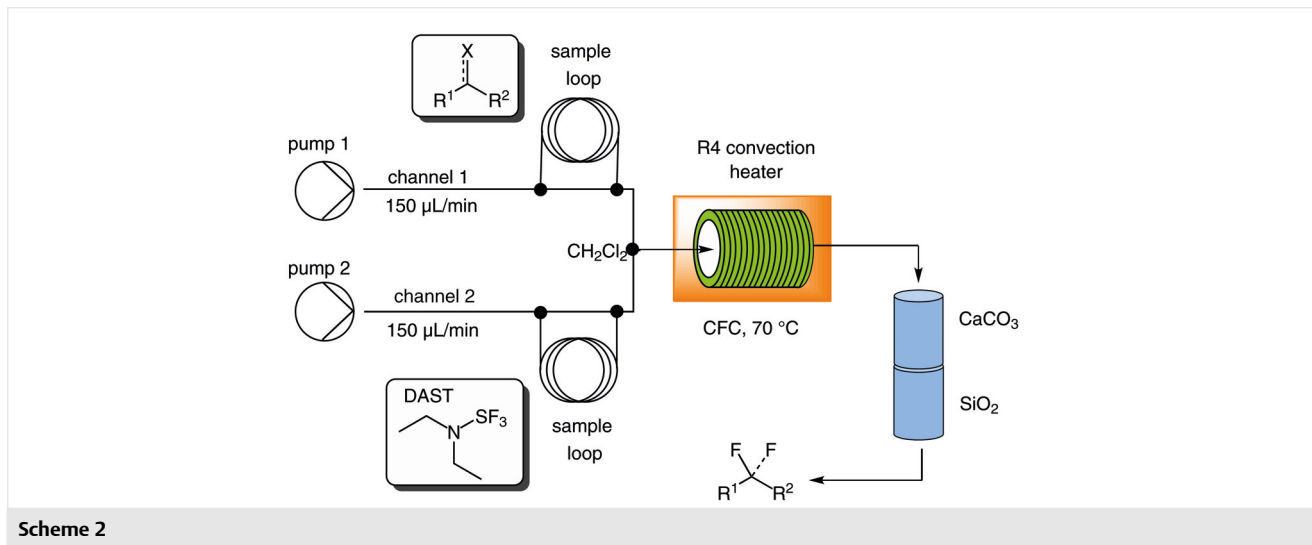

Figure 4



The use of flow systems that incorporate many of the now well-established methodologies began in about 2005 and have resulted in a substantial series of publications, many of which are incorporated in a review.⁴⁴ Due to space constraints I will mention only a small selection of those papers. The recent synthesis of the antimalarial candidate OZ439 (Figure 4, e) is just one example of the use of flow methods in synthesis.⁴⁵ It is interesting to note that flow technology has been developed to carry out reactions at both high⁴⁶ and low temperatures;⁴⁷ reactions that involve reactive intermediates include the generation of benzyne from anthranilic acid in the presence of furan with the reaction monitored by a micro-mass spectrometer.⁴⁸ Fluorination reactions using DAST⁴⁹ are illustrated in the diagram shown (Scheme 2).

The preparation of arylmagnesium reagents⁵⁰ and the carboxylation of Grignard reagents,⁵¹ involving flow methods, have also been developed, as well as the low tempera-

ture regioselective lithiation of a number of pyridine derivatives.⁵² The development of gas/liquid flow reactions has made use of a number of different tube-in-tube reactors⁵³ that include ozonolyses⁵⁴ and Glaser reactions.⁵⁵ Flow methods have been used in an interesting alternative synthesis of the tyrosine kinase inhibitor Imatinib and analogues as shown (Scheme 3).⁵⁶

It will be seen from this overview of Steve's work that he and his collaborators have made, and continue to make, an outstanding contribution to the development of modern organic chemistry.

I am grateful to a number of friends and colleagues who have helped by providing a number of anecdotes, photographs, and the flow diagrams.

Harry Heaney, Loughborough, December 2015

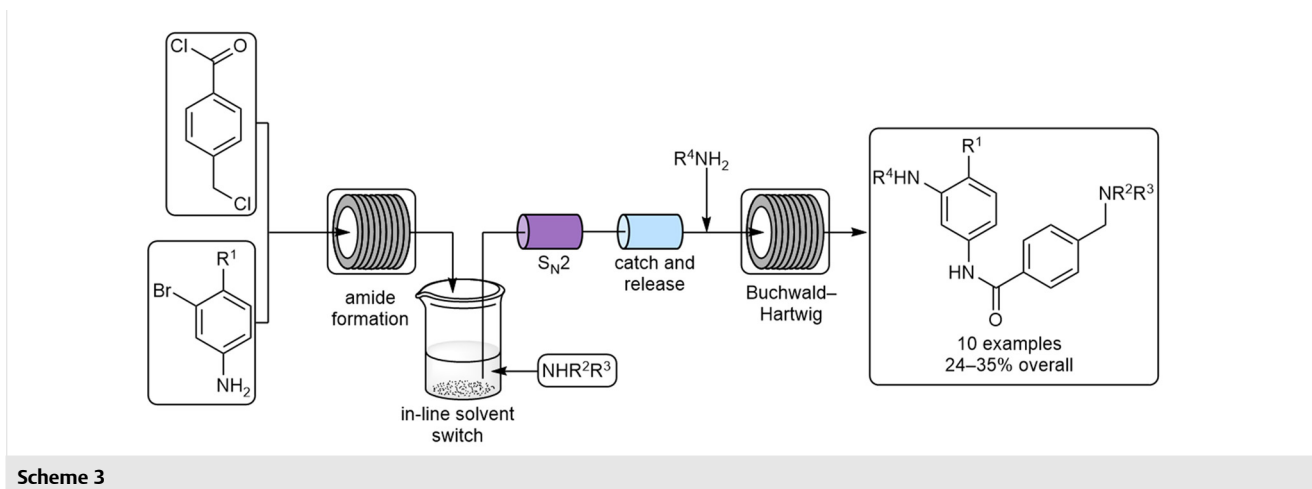

References and Notes

- (1) Heaney, H.; Ley, S. V. *J. Chem. Soc. D, Chem. Commun.* **1970**, 1184.
- (2) Heaney, H.; Ley, S. V.; Price, A. P.; Sharma, R. P. *Tetrahedron Lett.* **1972**, *13*, 3067.
- (3) Heaney, H.; Hollinshead, J. H.; Kirby, G. W.; Ley, S. V.; Sharma, R. P.; Bentley, K. W. *J. Chem. Soc., Perkin Trans. I* **1973**, 1840.
- (4) Heaney, H.; Ley, S. V. *J. Chem. Soc., Perkin Trans. I* **1973**, 499.
- (5) Paquette, L. A.; Ley, S. V.; Farnham, W. B. *J. Am. Chem. Soc.* **1974**, *96*, 312.
- (6) Ley, S. V.; Paquette, L. A. *J. Am. Chem. Soc.* **1974**, *96*, 6670.
- (7) Veitch, G. E.; Bridgwood, K. L.; Rands-Trevor, K.; Ley, S. V. *Synlett* **2008**, 2597.
- (8) Veitch, G. E.; Bridgwood, K. L.; Ley, S. V. *Org. Lett.* **2008**, *10*, 3623.
- (9) Barton, D. H. R.; Brewster, A. G.; Ley, S. V.; Rosenfeld, M. N. *J. Chem. Soc., Chem. Commun.* **1976**, 23, 985.
- (10) Barton, D. H. R.; Hui, R. A. H. F.; Ley, S. V. *J. Chem. Soc., Perkin Trans. I* **1982**, 2179.
- (11) Barton, D. H. R.; Bielska, M. T.; Cardoso, J. M.; Cussans, N. J.; Ley, S. V. *J. Chem. Soc., Perkin Trans. I* **1981**, 1840.
- (12) Griffiths, W. P.; Ley, S. V.; Whitecombe, G. P.; White, A. D. *J. Chem. Soc., Chem. Commun.* **1987**, 1625.
- (13) Ley, S. V.; Marsden, S. P.; Norman, J.; Griffith, W. P. *Synthesis* **1994**, 639.
- (14) Edwards, P. J.; Entwistle, D. A.; Genicot, C.; Ley, S. V.; Visentin, G. *Tetrahedron: Asymmetry* **1994**, *5*, 2609.
- (15) Ley, S. V.; Polara, A. *J. Org. Chem.* **2007**, *72*, 5943.
- (16) Annis, G. D.; Ley, S. V. *J. Chem. Soc. Chem. Commun.* **1977**, 581.
- (17) Annis, G. D.; Hebblethwaite, E. M.; Ley, S. V. *J. Chem. Soc., Chem. Commun.* **1980**, 297.
- (18) Hodgson, S. T.; Hollinshead, D. M.; Ley, S. V. *J. Chem. Soc., Chem. Commun.* **1984**, 494.
- (19) Edwards, M. P.; Ley, S. V.; Lister, S. G.; Palmer, B. D. *J. Chem. Soc., Chem. Commun.* **1983**, 630.
- (20) Ley, S. V.; Sternfeld, F. *Tetrahedron* **1989**, *45*, 3463.
- (21) Ley, S. V.; Anthony, N. J.; Armstrong, A.; Brasca, M. G.; Clarke, T.; Greck, C.; Grice, P.; Jones, A. B.; Lygo, B.; Madin, A.; Sheppard, R. N.; Slawin, A. M. Z.; Williams, D. J. *Tetrahedron* **1989**, *45*, 7161.
- (22) Edwards, M. P.; Ley, S. V.; Lister, S. G.; Palmer, B. D.; Williams, D. J. *J. Org. Chem.* **1984**, *49*, 3503.
- (23) Ley, S. V.; Simpkins, N. S.; Whittle, A. J. *J. Chem. Soc., Chem. Commun.* **1981**, 1001.
- (24) Ley, S. V.; Simpkins, N. S.; Whittle, A. J. *J. Chem. Soc., Chem. Commun.* **1983**, 503.
- (25) Brown, D. S.; Hansson, T.; Ley, S. V. *Synlett* **1990**, 48.
- (26) *The Neem Tree*; Schmutterer, H., Ed.; VCH Verlagsgesellschaft mbh: Weinheim, **1995**.
- (27) Bilton, J. N.; Broughton, H. B.; Ley, S. V.; Lidert, Z.; Morgan, E. D.; Rzepa, H. S.; Sheppard, R. N. *J. Chem. Soc., Chem. Commun.* **1985**, 968.
- (28) Broughton, H. B.; Ley, S. V.; Morgan, E. D.; Slawin, A. M. Z.; Williams, D. J. *J. Chem. Soc., Chem. Commun.* **1986**, 46.
- (29) Ley, S. V.; Lovell, H.; Williams, D. J. *J. Chem. Soc., Chem. Commun.* **1992**, 1304.
- (30) Bilton, J. N.; Jones, P. S.; Ley, S. V.; Robinson, N. G.; Sheppard, R. N. *Tetrahedron Lett.* **1988**, *29*, 1849.
- (31) (a) Veitch, G. E.; Beckmann, E.; Burke, B. J.; Boyer, A.; Maslen, S. L.; Ley, S. V. *Angew. Chem. Int. Ed.* **2007**, *46*, 7629. (b) Veitch, G. E.; Beckmann, E.; Burke, B. J.; Boyer, A.; Ayats, C.; Ley, S. V. *Angew. Chem. Int. Ed.* **2007**, *46*, 7633.
- (32) Ley, S. V.; Abad-Somovila, A.; Anderson, J. C.; Ayats, C.; Banteli, R.; Beckmann, E.; Boyer, A.; Brasca, M. G.; Brice, A.; Broughton, H.; Burke, B. J.; Cleator, E.; Craig, D.; Denholm, A. A.; Durand-Reville, T.; Gobbi, L. B.; Gröbel, M.; Gray, B. L.; Grossmann, R. B.; Gutteridge, C. E.; Hahn, N.; Harding, S. L.; Jennens, D. C.; Lovell, P. J.; Lovell, H. J.; de la Puente, M. L.; Kolb, H. C.; Koot, W.-J.; Maslen, S. L.; McCusker, C. F.; Mattes, A.; Pape, A. R.; Pinto, A.; Santfianos, D.; Scott, J. S.; Smith, S. C.; Somers, A. Q.; Spilling, C. D.; Stelzer, F.; Toogood, P. L.; Turner, R. M.; Veitch, G. E.; Wood, A.; Zumburn, C. *Chem. Eur. J.* **2008**, *14*, 10683.
- (33) (a) Veitch, G. E.; Pinto, A.; Boyer, A.; Beckmann, E.; Anderson, J. C. *Org. Lett.* **2008**, *10*, 569. (b) Boyer, A.; Veitch, G. E.; Beckmann, E.; Ley, S. V. *Angew. Chem. Int. Edn.* **2009**, *48*, 1317.
- (34) Veitch, G. E.; Boyer, A.; Ley, S. V. *Angew. Chem. Int. Ed.* **2008**, *47*, 9402.
- (35) Brittain, D. E. A.; Griffiths-Jones, C. M.; Linder, M. R.; Smith, M. D.; McCusker, C.; Barlow, J. S.; Akiyama, R.; Yasuda, K.; Ley, S. V. *Angew. Chem., Int. Ed.* **2005**, *44*, 2732.
- (36) Maddess, M. L.; Tackett, M. N.; Watanabe, H.; Brennan, P. E.; Spilling, C. D.; Scott, J. S.; Osborn, D. P.; Ley, S. V. *Angew. Chem. Int. Ed.* **2007**, *46*, 591.
- (37) Ley, S. V.; Tackett, M. N.; Maddess, M. L.; Anderson, J. C.; Brennan, P. E.; Cappi, M. W.; Heer, J. P.; Helgen, C.; Kori, M.; Kouklovsky, C.; Marsden, S. P.; Norman, J.; Osborn, D. P.; Palomero, M. Á.; Pavey, J. B. J.; Pinel, C.; Robinson, L. A.; Schnaubelt, J.; Scott, J. S.; Spilling, C. D.; Watanabe, H.; Wesson, K. E.; Willis, M. C. *Chem. Eur. J.* **2009**, *15*, 2874.
- (38) Frost, J. R.; Pearson, C. M.; Snaddon, T. M.; Booth, R. A.; Turner, R. M.; Gold, J.; Shaw, D. M.; Gaunt, M. J.; Ley, S. V. *Chem. Eur. J.* **2015**, *21*, 13261.
- (39) Ley, S. V.; O'Neil, I. A.; Low, C. M. R. *Tetrahedron* **1986**, *42*, 5363.
- (40) Ley, S. V.; Thomas, A. W.; Finch, H. J. *J. Chem. Soc., Perkin Trans. I* **1999**, 669.
- (41) Habermann, J.; Ley, S. V.; Scott, J. S. *J. Chem. Soc., Perkin Trans. I* **1999**, 1253.
- (42) Ley, S. V.; Baxendale, I. R. *Nat. Rev.* **2002**, *1*, 573.
- (43) Siu, J.; Baxendale, I. R.; Ley, S. V. *Org. Biomol. Chem.* **2004**, *2*, 160.
- (44) Ley, S. V.; Fitzpatrick, D. E.; Myers, R. M.; Battilocchio, C.; Ingham, R. J. *Angew. Chem. Int. Ed.* **2015**, *54*, 10122.
- (45) Lau, S.-H.; Galván, A.; Merchant, R. R.; Battilocchio, C.; Souto, J. A.; Berry, M. B.; Ley, S. V. *Org. Lett.* **2015**, *17*, 3218.
- (46) Deadman, B. J.; Browne, D. L.; Baxendale, I. R.; Ley, S. V. *Chem. Eng. Technol.* **2015**, *38*, 259.
- (47) Browne, D. L.; Baumann, M.; Harji, B. H.; Baxendale, I. R.; Ley, S. V. *Org. Lett.* **2011**, *13*, 3312.
- (48) Browne, D. L.; Wright, S.; Deadman, B. J.; Dunnage, S.; Baxendale, I. R.; Turner, R. M.; Ley, S. V. *Rapid Commun. Mass Spectrom.* **2012**, *26*, 1999.
- (49) Baumann, M.; Baxendale, I. R.; Ley, S. V. *Synlett* **2008**, 2111.
- (50) Brodmann, T.; Koos, P.; Metzger, A.; Knochel, P.; Ley, S. V. *Org. Process Res. Dev.* **2012**, *16*, 1102.
- (51) Polyzos, A.; O'Brien, M.; Pugaard-Petersen, T.; Baxendale, I. R.; Ley, S. V. *Angew. Chem. Int. Ed.* **2011**, *50*, 1190.
- (52) Baumann, M.; Baxendale, I. R.; Hornung, C. H.; Ley, S. V.; Rojo, M. V.; Roper, K. A. *Molecules* **2014**, *19*, 9736.
- (53) Brzozowski, M.; O'Brien, M.; Ley, S. V.; Polyzos, A. *Acc. Chem. Res.* **2015**, *48*, 349.
- (54) O'Brien, M.; Baxendale, I. R.; Ley, S. V. *Org. Lett.* **2010**, *12*, 1596.
- (55) Peterson, T. P.; Polyzos, A.; O'Brien, M.; Ulven, T.; Baxendale, I. R.; Ley, S. V. *ChemSusChem* **2012**, *5*, 274.
- (56) Hopkin, M. D.; Baxendale, I. R.; Ley, S. V. *Org. Biomol. Chem.* **2013**, *11*, 1822.